

GULF OF MEXICO

APPROVED BY RESOLUTION 2008-24  
 RECORDING DIVISION & PLANNING SECTION 21-151 &  
 21-162 OF THE PORT ARANSAS CITY CODE

**URBAN ENGINEERING**  
 CORPUS CHRISTI, TEXAS

JOB NO. 6100.A5.00      DATE: MAY, 2005

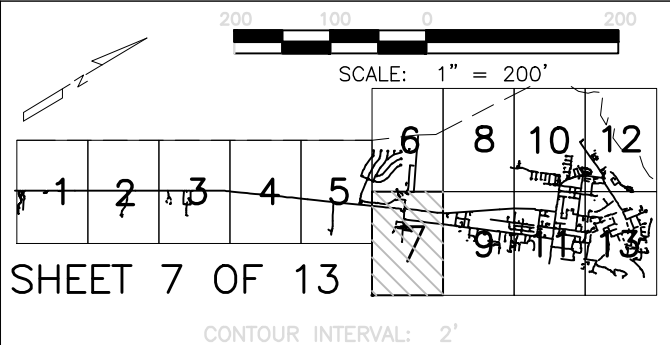

SHEET 7 OF 13

# CITY OF PORT ARANSAS DRAINAGE MASTER PLAN

PORT ARANSAS, TEXAS

LEGEND	
	MAIN DRAINAGE BOUNDARY
	DRAINAGE SUB-BOUNDARY
	PROP. DITCH
	EX. FLOW DIRECTION
	EX. HEADWALL
	PROP. CULVERT
	EX. CULVERT
	PROP. STORM SEWER w/INLET
	EX. MANHOLE
	PROP. MANHOLE
	CUMULATIVE DRAINAGE AREA (ACRES)
	STORM WATER RUN-OFF (cfs)
	HYDRAULIC GRADIENT
	PROP. FLOWLINE OF PIPE OR INLET
	PROP. FLOWLINE OF DITCH
	PROP. WIDTH OF DITCH BOTTOM
	PROP. TOP OF INLET
	PROP. SLOT ELEVATION
	QUANTITY & SIZE OF PROP. CULVERT
	DRAINAGE AREA (ACRES)
	EXIST. FLOWLINE OF PIPE OR INLET
	EXIST. TOP OF INLET
	EXIST. GRATE INLET ELEVATION
	EXIST. BOTTOM OF DITCH
	QUANTITY & SIZE OF EXIST. CULVERT
	SPOT ELEVATION (in DECIMAL)
	WATER SURFACE ELEVATION
	EDGE OF WATER
	INDEX CONTOUR & LABEL
	INDEX DEPRESSION CONTOUR
	HORIZ.-VERT. CONTROL PT.
	DIRT TRAIL OR ROAD
	FENCE
	RETAINING WALL
	CONCRETE SLAB
	TANK, OIL OR GAS WELL
	PROPERTY LINE